

# A K6STI low-noise receiving antenna for 80 and 160 meters

Here's how you can make a low-cost, low-noise, 21-foot-square receiving antenna that's certain to boost your DXability.

In his accompanying QST article,<sup>(1)</sup> Brian Beezley, K6STI, brings to our attention the details of how an antenna can be designed to eliminate (or greatly reduce) power-line noise to aid low-band reception. Brian's article includes the description of a 25-foot-square receiving antenna and matching section along with some observed operational characteristics. While Brian explored antenna design trade-offs with his computer software program, with his guidance, I built several prototype antennas. Here, I'll share the performance, operational and construction information I gained as Brian progressed to final design.

Although I had to shorten the sides of the antenna to 21 feet to fit my available real estate, the results achieved at my location in omnidirectional signal reception and power-line-noise cancellation with such a simple 10-foot-high antenna are remarkable! This deviation illustrates the fact that you can make substantial dimensional changes without performance degradation provided symmetry is maintained and the resulting feedpoint impedance is matched to the feed line.

The higher the Square, the greater its output level. After using a 21-foot Square on 160 meters, Brian and I are confident that small Squares can be made for each band and perform well. The antennas can be easily mounted on towers using horizontally positioned poles (such as quad antenna spreader poles<sup>(2)</sup>), or installed on posts as phased arrays to get directivity in a small area.

## The Test Location

The Square is an ideal antenna for hams living on small lots located near power lines that generate noise heard on the 40, 80 and 160-meter bands. My location is ideal for testing. It is between-and about one block from-the arms of a Y formed by a 30-year old, 6.9-kV ac San Diego Gas and Electric distribution system that has had its voltage increased without benefit of insulator upgrade, its load increased by changing to higher power-handling transformers without benefit of increased wire size, and its maintenance service decreased as the power company strives to reduce cost: a typical suburban area suffering from gradual hardware degradation that leads to line-noise generation. This area is located 12 miles from the Pacific Ocean and is subject to considerable day-to-day variations of temperature and humidity. During the test period, there was plenty of rain and the overall noise level was lower than normal, many times only S7 rather than the usual S9+. However, we still had multiple noise sources to deal with while observing Square performance.

My lot lacks sufficient space to install even a modest Beverage, but its pie shape permits the installation of two 80-meter  $\frac{1}{4}\lambda$  wave phased verticals,  $\frac{1}{4}\lambda$  apart, at the rear of the property. The verticals (with a gain of 4.9 dB) work well for transmitting, but when receiving, all signals-however strong-become victims of great batches of power-line noise. The noise sources are multiple and surround the location. Stations frequently can be heard, but not copied well-or at all.

## The Search for Quiet

Using a shortened 80-meter horizontal trap dipole at 84 feet and vertical rotary loops has not solved my noise problem. My two-element, full-size, 40-meter Yagi at 73 feet provides the best S/N, but the signals are very weak and my linear amplifier doesn't like it when I forget to throw the antenna switch before transmitting! It kicks off line and during the three-minute wait for it to return on line, I've usually lost the intended contact! I've been continually trying to improve reception with antennas, and have spent hundreds of dollars on black boxes. Both have helped on single noise sources, but they've been unable to cope with multiple noise sources.

## The EWE Antenna

A EWE antenna described by Floyd Koontz, WA2WVL, in QST<sup>(3)</sup> was undergoing tests when discussion of my results with Brian triggered his research that led to the Square design. I found the EWE to be a good antenna. I aligned its cardioid patterns on long path and short path, the same paths as my two  $\frac{1}{4}\lambda$  verticals. The vertical component of my line-noise sources, however, was still overwhelming when picked up by the two vertical portions of the EWE, leaving me with an unacceptable S/N. After the EWE, I tried a horizontal, 25-foot-per-side triangular antenna, 10 feet high. Noise was reduced from that picked up by the EWE, but was still more than I had hoped for. At this point, Brian decided on a square antenna design to get complete noise cancellation between both halves of the antenna. I then built the 21-foot Square.

## Scouting for Noise Sources

Once the antenna was ready, Brian visited my radio shack and, following a quick check, decided that we needed a survey of noise generation on the premises. I chased around turning off various devices to eliminate noise received on various antennas, or through the house wiring: We found several contributors. As a result, we recommend that you frequently survey your home and immediate surroundings to identify and eliminate noise from fluorescent light fixtures, variable voltage controls for lights, touch-controlled lamps, bug-killer traps, electric blankets, electronic air-purifying systems, packet terminals, computers and so on.

## Overall Performance Observations

Our survey showed us that reception of noise from ac noise sources within a household may not be eliminated or reduced by the Square (such noise may be delivered on, or radiated from, the ac lines strung through the house), but that power line noise about one block away will be. At my location, the Square antenna pattern appears to be omnidirectional and effective in reducing noise from multiple power-line sources. Summer-when everything dries out and arcing is everywhere-will test its omnidirectional capabilities to the utmost.

During testing, an unexpected bonus of the Square surfaced: We noticed that the antenna frequently drops background noise several S units. It's our assumption that this noise is a collection of lower-level suburban-area ac noise, so the effect we experienced may only be apparent in cities and towns. Whatever the sources, the noise reduction is a boon to reception. Theory and observations say that atmospheric noise and electrical-storm disturbances (noise crashes) won't be eliminated by the Square, but my Timewave DSP-9 audio filter helps lower atmospheric background noise level, and a noise blanker helps on certain types of repetitive impulse noise-even some types of power-line noise. The combination of the DSP-9 and the Square is more effective than either one alone.

## Performance

After a month of testing, I find that listening to SSB and CW signals on 80 and 160 meters is incredibly more comfortable using the Square, and I've been able to copy weak DX signals on the Square that I could hear-but not copy-using any of the other antennas. (An extract from my log is shown in Table I.) Although my 160-meter performance checks were not as exhaustive as those I performed on 80 meters, I compared my DX reception with the local 160-meter Big Guns daily and found that I could copy all the signals they heard, but for a shorter time during the window. I'm so encouraged with the results that I'm now erecting a vertical for transmitting.

It's important to realize that the Square is not a substitute for a directional antenna. If you can install long Beverages, do so. However, the omnidirectional nature of the Square may still come in handy in the absence of many Beverages if multiple noise sources exist.

## Construction

The Square is simple to build, install and tune. Figure 1 shows the Square as viewed from above. Here I'll tell you what's required to make 21-foot Squares for 80 and 160 meters, or a single Square that works on 80 or 160 meters at the flick of a switch.

Each Square is 21 feet on a side, 10 feet high and made of inexpensive #14 TW house wire. The antenna is fed at opposite corners using feeders made of 450-52 open-wire ladder line made with plastic spacers positioned about 6 inches apart. The two feed-line sections are each about 15 feet 6 inches long. Length isn't critical, but the sections must be of equal length to maintain antenna symmetry. Some sag in the lines is acceptable if they are cut long, but I prefer to cut the sections as exactly as possible and then pull the supporting lines taut to reduce wind whipping. Be sure to keep the antenna as square and level as possible in a horizontal plane even though the ground beneath the antenna slopes away.

At the Square's center, the two pieces of ladder line join inside a 4 x 6-inch plastic box and attach to the 4-turn primary winding of a matching transformer (T1) via a loop-resonating capacitor (see Figure 2). T1's secondary winding connects to an SO-239 connector from which 50 feet of RG-213 run to the shack. C1 can be placed at the middle of the primary winding to maintain symmetry. For ease of construction, however, I placed the capacitor in series with one side of the primary winding with no detectable performance degradation.

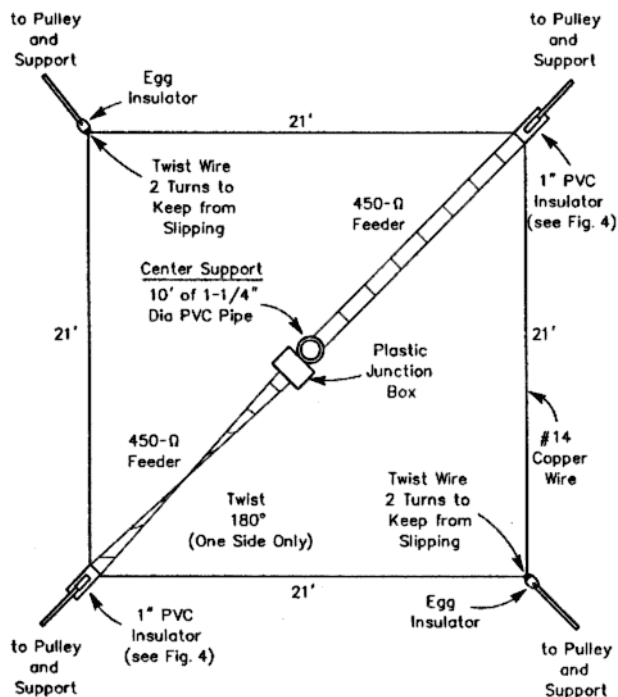

Figure 1-Looking down on the K6STI square - an 80 and 160 meter antenna that reduces interference from powerline noise. At W6KUT's location the antenna is installed at a height of 10 feet. A 10 foot long 1 1/4" diameter PVC pipe acts as a center support.

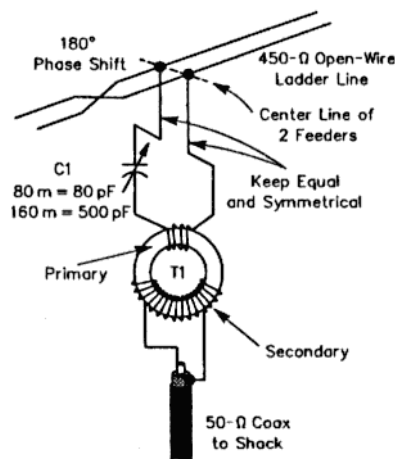

Figure 2-Details of the matching network for 80 and 160-meter single-band operation when using 450-a open-wire ladder line. This network is included inside the junction box (see Figure 1) of each 80 and 160-meter antenna.

(A Radio Shack 270-223 plastic box makes a suitable enclosure). C1 is a compression trimmer or air variable capacitor with a capacitance of 80 pF for 80 meters and 500 pF for 160 meters. C1 is connected in series with one leg of T1's primary winding. T1 consists of an FB-77-1024 ferrite shielding bead wound with #24 enameled wire. For 80 and 160 meters, the primary has 4 turns. The secondary winding consists of 10 turns for 80 meters and 20 turns for 160 meters.

Table 1 - Performance Comparison of the Antennas at W6KUT

	S Meter Readings for		
	Phased Verticals (no preamp)	Dipole at 84 ft (no preamp)	K6STI Square (20-dB preamp)
3814 kHz LSB'	9+	9+	8+
AM Noise	7.5	7.5	3
LSB Noise	6.5	5.5	1
CW Noise	6.5	5	0

Compare the noise-only S-meter readings with those of the signal + noise readings. Note: The S-meter readings were taken using a Yaesu FT-1000D equipped with a meter movement linear between S4 to S9. 'LSB signals from W5 area stations were being received on this frequency. Noise only for the various modes was measured on a clear frequency (3783 kHz). Filter bandwidths: AM, 6 kHz; LSB, 2.4 kHz; CW, 500 Hz.

For C1, I use a surplus compression trimmer that tunes above and below the resonance point. On 160 meters, a ¼-inch square, multi plate, mica-dielectric compression capacitor is used; its original capacitance range ran from 475 to 1800 pF. Calculations showed a need for about 475 pF, so I removed plates until there were only three per side and ended up with a capacitance range of 250 to 780 pF.

T1 consists of a primary and secondary winding of #24 enameled wire wound on an Amidon FB-77-1024 core. If your antenna has dimensions different from those shown-or if the feed-line section impedance is other than 450 a-you may have to experiment with the tap placements on T1 to find a match. If the dimensions and feed line are about the same as shown, the given turns numbers should work.

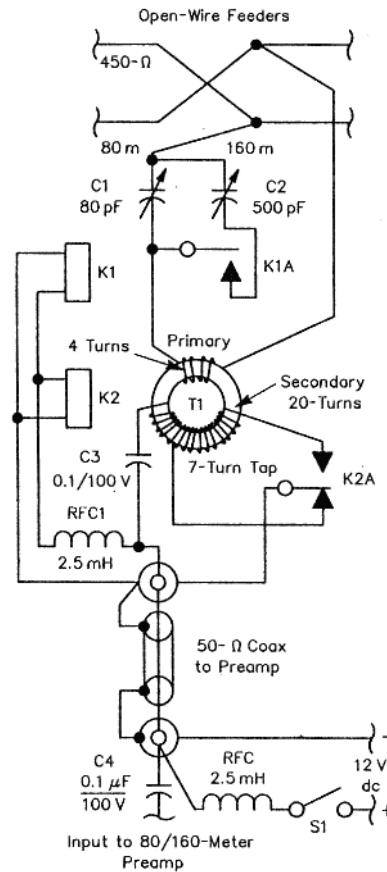
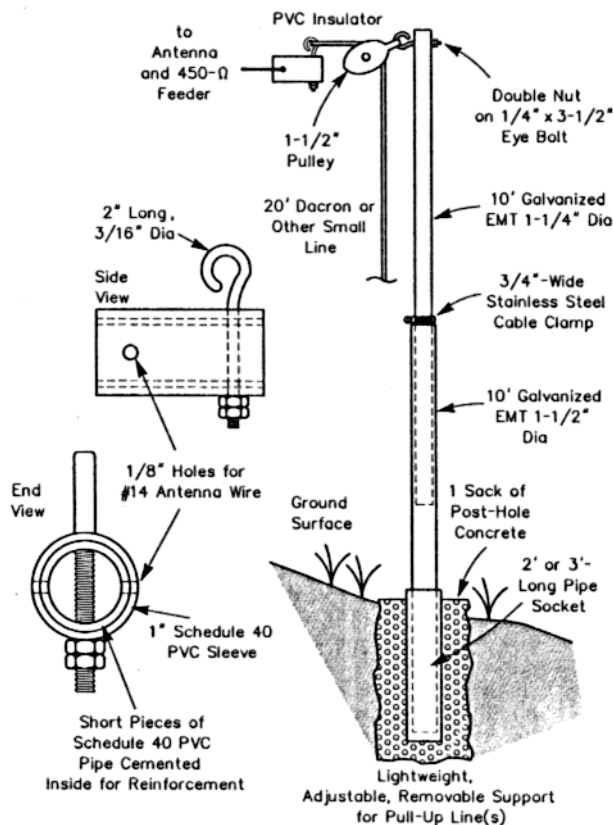

**Figure 3-Matching network for a duoband (80 and 160-meter) K6STI Square. Relays, powered through the coaxial-cable feed line, provide the required LC switching.**

- A Radio Shack 270-223 plastic box is used for the enclosure.
- C1 80-pF air variable capacitor or compression trimmer
- C2 500-pF air variable capacitor or compression trimmer
- C3, C4 0.1-μF, 100-V disc-ceramic capacitor
- K1 SPST relay, 12-V dc coil (Radio Shack 275-135)
- K2 SPDT relay, 12-V dc coil (Radio Shack 275-241)
- RFC1, RFC2 2.5 mH, 100 mA
- S1 SPST toggle switch
- T1 Amidon FB-77-1024 shielding bead wound with #24 enameled wire; 4-turn primary, 20-turn secondary, with a tap at the 7th turn.

Figure 3 illustrates how the feed system for my antenna is matched for both 80 and 160 meters. An SPST switch and a 2.5 mH RF choke provide relay operating voltage via the feed line. This permits remote selection of 80 and 160-meter operation. At the antenna end, dc flows through another RF choke. C3 and C4 are 0.1 μF blocking capacitors used to protect the input of the preamplifier or receiver from the relay operating voltage and to keep from shorting the dc to ground in the junction box.

Two relays are used to permit best symmetry on the feed-line side where additional capacitance is added for 160-meter operation using an SPST relay. Selection of a 7 turn tap for 80 meters or a full 20 turns for 160 meters requires an SPDT relay. (Note: If an 80 meter transformer only is made, use four turns on the antenna side and 10 turns on the feed-line side). Small, 12 V dc relays are available from many surplus houses and from Radio Shack for less than \$2 each.



**Figure 4-A lightweight, adjustable, removable support for pull-up lines. The inset shows the construction of two homemade PVC insulators; one is required at each point the feed line connects to the antenna and then to the support.**

Figure 4 shows an inexpensive, removable and adjustable support pole and homemade PVC insulators used to hang the Square. The junction box containing the matching network is supported by a 10-foot-length of 2 1/4-inch schedule 40 PVC pipe. A reducer and an 18-inch-long detachable 1/4 inch diameter PVC extension are attached to the box. The pole is set 18 inches into the ground at the center of the Square. The removable extension permits you to build the antenna at ground level, then raise or lower it as needed with the pulleys. The Dacron line I use to raise and lower the antenna has proved itself reliable during years of service and I recommend it.<sup>(4)</sup>

When assembling the Square, remember that one of the open-wire feed lines must be rotated 180° to obtain power-line noise cancellation by the two halves. To get good noise cancellation, maintaining symmetry in the two halves of the antenna is important. Maintain symmetry in each antenna leg, from the start of the two feed-line sections to the center junction, and from the junction to the matching transformer winding inside.

## Tuning the Square

We used an MFJ-208 HF/VHF SWR analyzer and a Startek 35-BG frequency counter to tune the antenna, by feeding output of the analyzer to the coax connector or feed line from the shack. (Any of the presently available antenna analyzers should do the job.) Using the given values, all that should be necessary is to sweep the frequency range and find the meter dip. (Use an insulated tuning wand to eliminate hand-capacitance effects when adjusting compression trimmer capacitors.) The frequencies should bracket 3650 kHz for 80 meters. If they don't, use a different value of capacitance. Set the oscillator to 3650 kHz and adjust the capacitor to get a minimum SWR; 1:1 should be possible within the capacitor's range. If an SWR of 1:1 isn't achievable, TI's turns ratio may require adjustment. A turns ratio change should be required only if a major change is made in antenna or feed-line geometry.

I don't recommend using a transceiver for tuning the antenna because the matching network capacitor's dielectric may be punctured. If you do use your transceiver, keep the output power at its lowest level. However, we found that because of the low power output from the MFJ, AEA and other antenna analyzers, the reflected power reading on 160 meters can be misleading where significant fundamental, or harmonic, broad-cast-station RF is present. This energy is detected and indicates as reflected power; the indicator registers full scale and nulls aren't visible. At K6TQ, with his 135-foot-tall, 6-inch-diameter vertical, a nearby broadcast station on 1000 kHz overwhelmed the MFJ and AEA instruments, so we resorted to using a transceiver. At my location, no broadcast signals interfered with the Square during testing.

For the two-band antenna, first tune the 80-meter section as described previously, then activate the relays (applying battery voltage locally) and adjust C1 for a 1:1 SWR at 1870 kHz.

## Pre-amplifier

I pressed into service a homemade, all-band, three-pole band-pass filter used in multi-multi contest operations. The filter enclosure also contains a 20-dB pre-amplifier. I prefer a gain of 20 dB to keep levels within a reasonable range when switching between antennas. I have not found the band-pass filters to be of any help on receiving with the Square at my location. W6YA, however, installed an 80-meter band-pass filter to solve local AM broadcast station overload when using his horizontal 80-meter dipole.

## Selecting Feed-Line Material

Our first tests were conducted using currently available 450 $\Omega$  feed line manufactured with alternating 1½-inch open spaces and 1½-inch-long plastic sections (50% coverage). During our evaluation, we found that by setting the Square's resonance at 3650 kHz, we got S-meter readings at 3500 and 3800 kHz that were only about two S units down from resonance peak, and, with minor receiver-gain adjustment, there was no noticeable change during operation. We also found that resonance would drop about 200 kHz when the feed line was wet from heavy condensation or rain (San Diego never has ice, so that condition wasn't tested!). The 200-kHz excursion seemed a bit excessive, so we tried exterior 300 $\Omega$  TV line installed in a section of ¼-inch PVC tubing between the center and antenna feed-line connection points. This proved mechanically ungainly, but worse, matching-network requirements became very difficult to achieve with available components, so we abandoned the use of 300 $\Omega$  line.

Knowing that a large impedance variation exists from one end of the feed lines to the center, Brian dug out some old ladder line. It has small plastic spacers 6 inches apart and a conductor spacing of about 1 inch. We calculated the impedance of Brian's open ladder line to be 500 $\Omega$ , and two pieces of this line were installed without support, the antenna ends being pulled taut. Resonance shifted only from 3650 to 3495 kHz from dry to soaking wet, an acceptable shift. On 160 meters, the resonance shift was about half that of 80 meters.

It's important to realize that a shift in resonance will only cause a variation in signal level, not a change in S/N. We can easily tolerate a bad-weather resonance shift resulting in some reduction of level, but not a loss of S/N. The resulting SWR change is meaningless since we're not transmitting with the antenna. A small loss of signal level is the only penalty, and it's easily recovered by a tweak of the audio control.

## Summary

A leading supplier of wire and cable reports that quality control of available open-wire line of the type we chose to use is poor, and that the spacers tend to fall off easily. If such line is used, find some way of securing the spacers.<sup>[5]</sup> In the future, we may make our feed lines using #14 wire with a conductor spacing of 2 to 4 inches and homemade spacers. A change in matching transformer turns ratio and resonating capacitor values may be required. Brian's configurations have kept the size of horizontal loop and feed-line impedances such that only a capacitor is needed to resonate the loop.

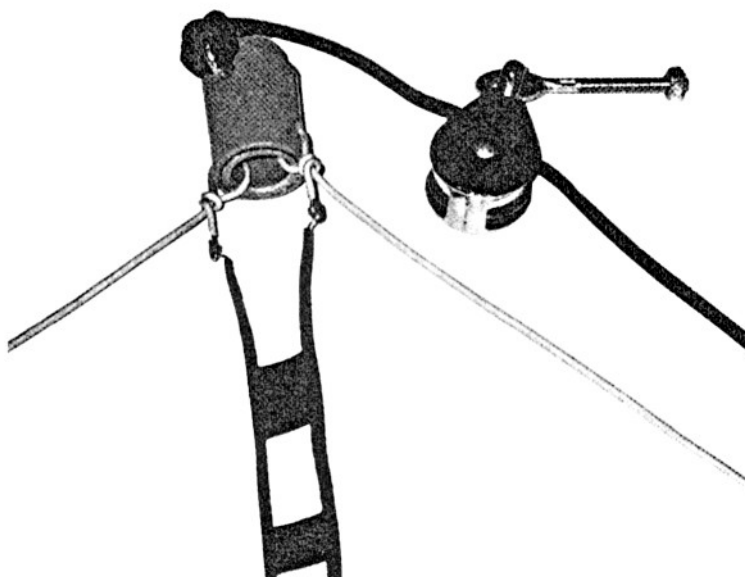

**Figure 5-Attachment of the 450  $\Omega$  line to the antenna arms and homemade PVC support insulator.**

Brian feels that if the Square is raised to 20 feet to improve signal strength, feed lines could come down at an angle to a 10-foot-center pole (so that tuning could be easily achieved) without seriously degrading performance. This has not been tested.

If anyone builds a Square antenna and finds it caked in ice one day, please let Brian or me know what happens to the Square's resonance! Have fun constructing-and pleasant listening!

## Notes

1. Brian Beezley, K6STI, "A Receiving Antenna That Rejects Local Noise," QST, elsewhere in this issue.
2. For information on fiberglass spreader sources, see The ARRL Antenna Book, 17th edition, page 21-6. Other sources include: Eur-Am, PO Box 990, Meredith, NH 032530990, tel 603-279-1394, and NCG Co-Comet Antenna, 1275 North Grove St, Anaheim, CA 92806, tel 800-962-2611, 714-630- 4541, fax 714-630-7024.
3. Floyd Koontz, WA2WVL, "Is this EWE for You?", QST, Feb 1995, pp 31-32.
4. Synthetic Textiles Inc, 2472 Eastman Ave, Ventura, CA 93003, tel 805-658-7903, fax 805-658-7620.
5. Several tips on securing open-wire feed-line spacers have appeared in the Hints and Kinks column. For starters, see Glenn E. Yingling, W2UW, "Kinky Wire Aids Building Open-Wire Feed Line," Hints and Kinks, QST, Sep 94, p. 94.ICJ